



SANTOS[®]

Food and Beverage
Equipment Provider



French

**MANUFACTURER
OF FOOD, COFFEE, BAR
AND JUICE EQUIPMENT**

Fabricant français de matériel
professionnel pour bars à jus, coffee
shops, bars et restaurants

handmade
IN FRANCE

2023 – 2024

SANTOS, 65 YEARS OF HISTORY

SANTOS, 65 ANS D'HISTOIRE

Who are we?

Qui sommes-nous ? 04

JUICE BAR EQUIPMENT

ÉQUIPEMENTS POUR BAR À JUS 06

Citrus juicers

Presse-agrumes 08

Juice extractors and Cold press juicer

Extracteurs de jus par centrifugation
et pression lente 10

Our main accessories

Nos accessoires principaux 12

BAR EQUIPMENT

ÉQUIPEMENTS DE BAR 14

Blenders and Drink dispenser

Blenders et Distributeur de boissons 16

Ice crushers

Broyeurs à glaçons 18

Our main accessories

Nos accessoires principaux 19

KITCHEN EQUIPMENT

ÉQUIPEMENTS DE CUISINE 20

Grater, Dough mixers and Meat mincer

Râpe, Pétrin et Hachoir à viande 22

Blender

Blender 23

Our main accessories

Nos accessoires principaux 24

COFFEE SHOP EQUIPMENT

ÉQUIPEMENTS POUR COFFEE SHOPS 26

Espresso coffee grinders

Moulins à café expresso 28

Coffee shop grinders

Moulins à café boutique 30

Our main accessories

Nos accessoires principaux 32

Technical data

Données techniques 34



GAMME JUS

Juice range



GAMME BAR

Bar range



GAMME CUISINE

Food range

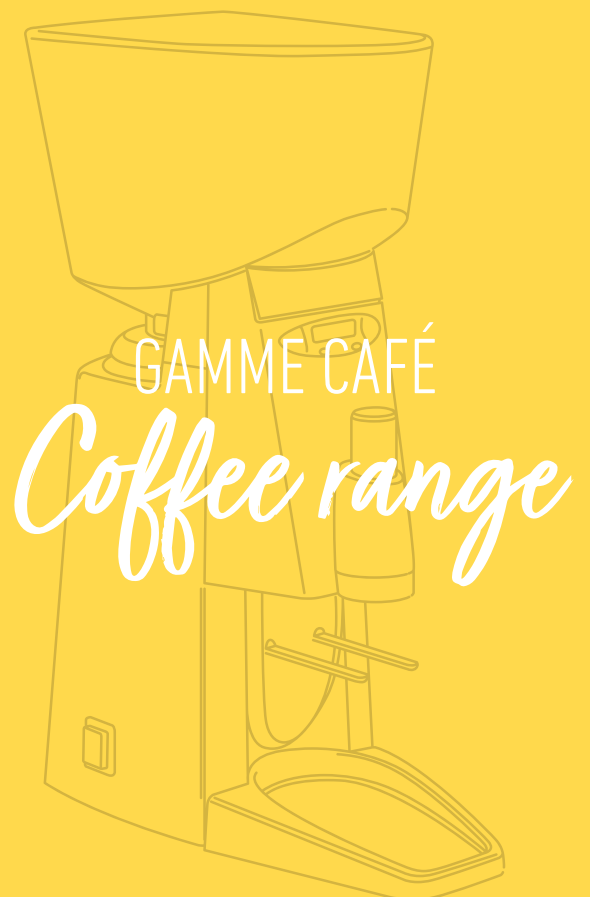

GAMME CAFÉ

Coffee range



65 YEARS OF HISTORY

Santos, French manufacturer of food, coffee and juice equipment was created in 1954, by André Fouquet.

Originally, the company was providing professional coffee grinders and cheese graters to small retailers. 65 years after the launch of its first products, Santos continues to grow and the R&D department develops new and innovative products based on our savoir-faire with respect to production of motors. This is one of the reasons why Santos products are reputed for their robustness and reliability.

65 ANS D'HISTOIRE

Santos, fabricant français de matériel électrique pour la préparation culinaire, le café et les boissons fraîches, a été créé en 1954, par André Fouquet.

À l'origine, l'entreprise produisait des moulins à café et des râpes à fromage professionnels pour les épiceries de quartier. 65 ans après le lancement de ses premiers produits, Santos poursuit son développement en concevant des produits innovants basés sur son savoir-faire en matière de production et de bobinage des moteurs. C'est certainement l'une des raisons pour laquelle la marque Santos est réputée fiable et robuste.



WORLDWIDE NETWORK AND EXPERIENCE

Santos is now represented in more than 130 countries thanks to its network of resellers and importers who contribute to the success of our brand and products on their markets.

We participate in the most important tradeshows all over the world and develop our products to answer the needs of professionals in Europe, Asia, the Middle East, USA...

UNE EXPÉRIENCE ET UN RÉSEAU AU NIVEAU MONDIAL

Notre réseau international de revendeurs et d'importateurs représente avec succès la marque et les produits Santos dans plus de 130 pays.

Nous participons aux principaux salons professionnels dans le monde entier et nous développons nos produits pour répondre aux besoins de nos clients en Europe, en Asie, au Moyen Orient, aux Etats-Unis...



QUALITY, STANDARDS, SERVICE

The thousands of high quality appliances that are produced in our factory are in accordance with the most stringent international regulations (UL, GS, CE, NSF, KC, etc.)* and can be adapted to all relevant voltages. Besides developing high quality products, our goal is to provide the best commercial and after-sales services. We know that your satisfaction depends on our efficiency.

QUALITÉ, NORMES, SERVICE

Les milliers d'appareils qui sont fabriqués dans notre atelier respectent les normes internationales les plus strictes (UL, GS, CE, NSF, KC, etc.)** et peuvent être adaptés à tous les voltages locaux.

Notre objectif est de vous fournir un service de qualité en complément de notre gamme de produits. Nous savons que votre satisfaction dépend de notre efficacité.

*voir liste exhaustive sur le site internet www.santos.fr

**see exhaustive list on website www.santos.fr

Handmade
IN FRANCE



MADE IN FRANCE

Offering high quality products 100% made in France has always been a priority for Santos. Since 1954, all our machines are designed and manufactured in our factory in Lyon, and our network of suppliers is local.

Santos appliances are hand-made by operators that are responsible for the appliance from the beginning of the production to the final control (100% tested after assembly).

Our solid international experience allows us to be very flexible, we always keep a maximum of items in stock, and we are able to meet tight deadlines.

FABRICATION FRANÇAISE

Santos a toujours accordé une grande importance à la fabrication 100% française de ses appareils.

Depuis le début de l'aventure, en 1954, les produits Santos sont développés et fabriqués dans notre atelier, à Lyon, et notre réseau de fournisseurs est local.

Tous les produits sont montés par des opérateurs qui sont responsables des appareils du début de leur production jusqu'au contrôle final (100% testés en fin de fabrication).

Notre solide expérience internationale nous permet d'être très flexibles et nous sommes en mesure de garantir des délais courts avec un stock complet et diversifié.

Service
expertise

INNOVATION, DESIGN AND ECO-CONCEPTION

Year after year, we develop innovative appliances that are the result of our market experience since 1954.

We focus more and more on developing eco-friendly products, integrating innovative technologies, to meet the needs of our customers: first company to launch a brushless motor in a blender which offers increased longevity and lower power consumption, food-zone materials without bisphenol A, packaging in moulded cellulose... In an eco-friendly approach, we use recyclable materials, such as stainless steel and aluminum, in order to combine robustness and respect for the environment.

Also, our appliances are built to last thanks to their design and the quality of their materials. We guarantee the availability of all spare parts for more than 10 years after the production of our appliances, so that they are durable and endlessly repairable. Recently, Santos has achieved the Longtime® certification for its products. LONGTIME® is the European label for products designed to last. The certification, deliver by an independent control laboratory (and based on 41 requirements), it provides assurance that products are reliable and repairable.



+ Green
technology

INNOVATION, DESIGN ET ÉCO-CONCEPTION

Années après années, nous développons des appareils innovants qui sont le fruit de notre expérience du marché depuis 1954.

Nous attachons toujours plus d'importance au développement de produits respectueux de l'environnement, intégrant des technologies innovantes, pour répondre aux besoins de nos clients : première entreprise à développer un moteur brushless dans un blender offrant une longévité accrue et une consommation électrique plus faible, matériaux en zone alimentaire sans bisphénol A, emballages en cellulose moulée... Dans une démarche eco-responsable, nous utilisons des matériaux recyclables, tels que l'acier inoxydable et l'aluminium, afin d'allier robustesse et respect de l'environnement.

De plus, par leur conception et la qualité des matériaux utilisés, nos appareils sont conçus pour durer. Nous garantissons la disponibilité de toutes les pièces détachées plus de 10 ans après la fabrication de nos appareils, pour qu'ils soient durables et réparables à l'infini. Récemment, Santos a acquis la certification Longtime pour ses produits. Longtime® est le label européen des produits conçus pour durer. Délivrée par un organisme de contrôle indépendant (et basé sur un référentiel de 41 critères transverses), il garantit la robustesse et la réparabilité des produits certifiés.

Juice Bar Equipment Équipements pour bar à jus

Santos is the juicing
equipment specialist since
1954 and provides a wide
range of juicers for all needs!

Santos est le spécialiste
de l'extraction de jus depuis
1954 et propose une large
gamme d'équipements pour
répondre à tous les besoins !



68

Juice extractor *Miracle Edition*

**Extract juice from various
fruits and vegetables (like
apples, carrots, pineapples...)**

L'extracteur de jus par centrifugation *Miracle Edition*

Faites du jus de tous types de
fruits et légumes (ex. pommes,
carottes, ananas...)

Healthy
and fresh



70

Citrus juicer Evolution
Make fresh orange,
grapefruit or lemon juice

**Presse-agrumes à levier
évolution**

Réalisez des jus d'oranges,
de pamplemousses ou de
citrons

65

Cold Press Juicer
Prepare fresh cold pressed
juices from fruits, veggies,
and leafy greens

**Extracteur de jus
à pression lente**

Préparez des jus pressés
à froid à base de fruits,
légumes et herbes

A wide range of citrus juicers

UNE LARGE GAMME
DE PRESSE-AGRUMES



11



30l/h



11
Green
Vert



11 G
Grey
Gris



11 C
Chrome
Chromé

Since 1954
Depuis 1954



The genuine citrus juicer

Classic citrus juicer (3 squeezers + cover)
Painted base 11-11G or chromed base 11C

L'authentique presse-agrumes professionnel
Presse-agrumes Classic (3 ogives + couvercle)
Socle peint 11-11G ou socle chromé 11C

71C



30l/h



38
Green
Vert



38 G
Grey
Gris



38 C
Chrome
Chromé

38G



Citrus juicer (3 squeezers + cover)

Painted base 38-38G or chromed base 38C

Presse-agrumes (3 ogives + couvercle)
Socle peint 38-38G ou socle chromé 38C



15l/h



71C
Grey
Gris



Mefra citrus juicer (1 squeezer)
Grey base 71C

Presse-agrumes Mefra (1 ogive)
Socle gris 71C

70



- Easy to clean
- Accepts all kinds of glasses and jugs
- Squeezer adapted to all kinds of citrus

- Facile à nettoyer
- Accepte tous types de verres et pichets
- Ogive adaptée à tous les agrumes



50l/h



70
Grey
Gris

Lever juicer Evolution 70 (1 squeezer)
Painted (70)

Presse-agrumes à levier 70 Evolution (1 ogive)
Cuve et socle peints (70)



52C



40l/h



52G
Grey
Gris



52C
Chrome
Chromé

High output Citrus juicer (3 squeezers)
Painted base 52G or chromed base 52C
Accepts all kinds of glasses and jugs

Presse-agrumes gros débit (3 ogives)
Socle peint 52G ou socle chromé 52C
Accepte tous types de verres et pichets

10C



30l/h



10
Grey
Gris



10C
Chrome
Chromé

Automatic citrus juicer with lever (1 squeezer)
Painted 10 or chromed 10C

Presse-agrumes à levier (1 ogive)
Cuve et socle peints 10 ou chromés 10C

We have the juice extractor you need

L'EXTRACTEUR DE JUS
PAR CENTRIFUGATION
QU'IL VOUS FAUT



68



68 J
Juice bar version:
delivered with
pulp tube
Version bar à jus:
livrée avec
un tube
d'évacuation



140l/h



68
Stainless
steel
Inox

**New generation
centrifugal juice extractor *Miracle Edition***
Perfect filtration + wide feeding chute

**Extracteur par centrifugation
nouvelle génération *Miracle Edition***
Filtration parfaite + large introduction



↑ **Equipped with the Ezy-clean™
system:** removable bowl and
basket.
↓ **Équipées du système
Ezy-clean™ :** panier et cuve
amovibles.

28



100l/h



28
Stainless
steel
Inox

Centrifugal juice extractor
Perfect filtration

Extracteur par centrifugation
Filtration parfaite

50



100l/h



50
Black
Noir



50C
Chrome
Chromé



Centrifugal juice extractor
Painted 50 or chromed base 50 C
Perfect filtration + wide feeding chute

Extracteur par centrifugation
Socle peint 50 ou socle chromé 50 C
Filtration parfaite + large introduction



New
Nouvelle
version

65

COLD PRESSED JUICES!

JUS PRESSÉS
À FROID!

Heavy duty counter-top cold press juicer for fruits, veggies and leafy greens.

XL feeding tube.

Extracteur de jus puissant pour fruits, légumes et herbes.

Goulotte d'introduction XL.



60l/h



65
Stainless
steel
Inox



Cold Press Juicer

Speed variation (+ 1 filter)

Extracteur à pression lente

Variation de vitesse (+ 1 filtre)

DIFFERENT TYPES OF JUICE EXTRACTION

DIFFÉRENTES
MÉTHODES
D'EXTRACTION

There are different processes to extract juice from fruits and vegetables.

Find the juicer adapted to your needs.

Il existe différents procédés permettant d'extraire le jus de fruits et légumes.

Trouvez l'appareil adapté à vos besoins.

Squeeze Pressage

70 Citrus juicer
Presse-agrumes



This juicer squeezes oranges, grapefruits, lemons and pomegranates. It is suitable for intensive use thanks to its high output.

Permet de presser les oranges, pamplemousses, citrons et grenades. Il est adapté à un usage intensif grâce à son débit élevé.

Centrifuge Centrifugation

68 Juice extractor
Extracteur par centrifugation



Using centrifugal force, it extracts juice from various types of fruits and vegetables such as apples, carrots, beetroots... It is adapted to intensive use.

Par l'intermédiaire de la force centrifuge, elle extrait le jus de fruits et légumes variés tels que les pommes, carottes, betteraves... Elle est adaptée à une utilisation intensive.

Slow press Pression lente

65 Cold press juicer
Extracteur à pression lente



It presses very slowly all kinds of fruits, vegetables, and herbs, to extract maximum juice and to preserve vitamins and nutrients.

Presse très lentement les fruits, légumes et herbes pour en extraire un maximum de jus, tout en préservant les vitamines et les nutriments.

Juice equipment

L'équipement jus

Our main accessories
Nos accessoires principaux

CITRUS JUICERS PRESSE-AGRUMES



11



Squeezer for grapefruit
Ogive Pamplemousse
Ref #11103 - #38102



Squeezer for limes
Ogive citron vert
Ref #11150 - #38150



Squeezer for orange + lemon
Ogive orange + citron
Ref #11101 - #38101



38



Yellow bowl
Cuve jaune
Ref #11204NJ - 38203NJ



Black bowl
Cuve noire
Ref #11204NN



Plastic filter grid
Grille plastique
Ref #11201- #38201



Ornamental ring
Cercle anodisé
Ref #11202 - #38202



52 C



Squeezer for grapefruit
Ogive Pamplemousse
Ref #52200



Squeezer for limes
Ogive citron vert
Ref #52150



Squeezer for orange + lemon
Ogive orange + citron
Ref #52100



Stainless steel bowl
Cuve inox
Ref #52301



Anti splash dome
Dome anti projection
Ref #52303



Stainless steel pulp grid
Grille à pulpe inox
Ref #52302



10



Complete squeezer
Ogive complète
Ref #10200



70



Complete squeezer
Ogive complète
Ref #70200

JUICE EXTRACTORS EXTRACTEUR DE JUS PAR CENTRIFUGATION



68



Basket: holes 0,5mm
Panier : trous 0,5mm
Ref #68200



Basket: holes 0,8mm
Panier : trous 0,8mm
Ref #68200B



Autoclean basket
Panier autoclean
Ref #68200C



Pulp tube
Tube à pulpe
Ref #68960



Kit Chefs & Pâtisserie
Kit Chefs et pâtisserie
Ref #68110



50



Basket: holes 0,5mm
Panier : trous 0,5mm
Ref #50200



Basket: holes 0,8mm
Panier : trous 0,8mm
Ref #50200B



Autoclean basket
Panier autoclean
Ref #50200C

COLD PRESS JUICER EXTRACTEUR DE JUS À PRESSION LENTE



65



Complete wiper
Racleur complet
Ref #65260



Complete 0,3 filter
Filtre complet 0,3
Ref #65220



Pulp tube
Tube à pulpe
Ref #65105



Base tube
Tube de socle
Ref #65108

Bar equipment Équipements de bar

Find the right equipment for your cocktails! Crush, mix, blend, emulsify your ingredients, for the perfect drink!

Trouvez l'équipement adapté à vos cocktails ! Broyez, mixez, mélangez, émulsionnez vos ingrédients pour des boissons parfaites !



*Let's have
a drink!*

53

Ice Crusher

Crush ice cubes for your cocktails and granitas

Broyeur à glaçons

Broyez des glaçons pour vos cocktails et granitas



54

Drink mixer

Prepare milkshakes and all types of creamy and frozen cocktails

Shaker électrique

Préparez des milkshakes et toutes sortes de cocktails crémeux et glacés

66

Compact Brushless Blender

Blend your cocktails, smoothies, frozen drinks...

Blender Brushless compact

Mixez vos cocktails, smoothies, boissons glacés...

62

Expert Brushless Blender

Make your frozen cocktails, with ice cubes and frozen fruits

Blender Brushless Expert

Mixez vos cocktails glacés, avec des glaçons et fruits congelés

Everything for the bar

| TOUT POUR LE BAR



62

Black
Noir

Compact brushless blender

Equipped with the quiet blending technology and a unique lid detection, this powerful, heavy duty and compact blender can quickly crush any kind of ingredients

Blender Brushless compact

Extrêmement silencieux et doté d'une détection de couvercle unique, ce blender puissant et compact peut broyer et mixer toutes sortes d'ingrédients

62



62

Black
Noir

Expert Brushless blender

Extremely efficient, silent and easy to use, it is the perfect appliance to make smoothies and iced drinks. It crushes all kinds of ice cubes.

Blender brushless Expert

Extrêmement performant, silencieux et simple à utiliser, il est l'outil parfait pour réaliser les smoothies et boissons glacées. Il broie tous types de glaçons.

Brushless motor

MOTEUR
BRUSHLESS

Brushless motor: extended life expectancy, excellent energy efficiency, low noise level, no overheating.

Moteur brushless : très grande durée de vie, excellent rendement énergétique, faible niveau sonore et pas de surchauffe.

54



54 NEM
Black
Noir



54
Black
Noir



Drink mixer, electric shaker
Speed variation, 2 bowls - 3 tools

Shaker électrique, drink mixer
Variation de vitesse, 2 bols - 3 agitateurs

33 GE



33E
Green
Vert



33GE
Grey
Gris



33CE
Chrome
Chromé



Bar blender 33 Evolution (1.25 litre container)
Painted base 33E - 33GE or chromed base 33CE

Mixer de bar 33 Evolution (bol 1,25 litre)
Socle peint 33E - 33GE ou socle chromé 33CE

34-1



34-1
Stainless
steel
Inox

Cold drink dispenser (1 bowl x 12 l)
Available with 2 bowls 34-2 or 3 bowls 34-3
Accepts fruit pieces, High quality compressor

Distributeur de boissons réfrigérées (1 bac x 12 l)
Disponible avec 2 bacs 34-2 ou 3 bacs 34-3
Accepte les morceaux de fruits, compresseur
haute qualité



Bar essential

L'INCONTOURNABLE
POUR VOTRE BAR

It is adapted to intensive use
and allows a hands free use
thanks to its high capacity tank
1.2kg.

Adapté à une utilisation intensive
et permet un fonctionnement
« main libres » grâce à son
réservoir à glaçons de 1,2 kg.



09



09
Beige
Beige

Traditional Ice shaver

Delivered with one adjustable disc for snow ice
and crushed ice.

Broyeur à glaçons traditionnel

Livré avec un disque réglable pour neige et
glace pilée.

53



53
Grey
Gris

Ice crusher

Two sizes of crushed ice. Perfect for cocktails
(caipirinhas, mojitos...)

Broyeur à glaçons

2 tailles de glace pilée. Parfait pour les cocktails
(caipirinhas, mojitos, ...)

Bar equipment

L'équipement bar

Our main accessories
Nos accessoires principaux

BRUSHLESS BLENDERS BLENDEURS BRUSHLESS



62



66

Complete bowl
Bol complet
Ref #62100 -
#66100

Complete yellow bowl
Bol complet
jaune
Ref #62100Y -
#66100Y

Complete red bowl
Bol complet
rouge
Ref #62100R -
#66100R

Complete blade
Ensemble
couteaux
Ref #62110 - #66110

Tightening tool
Outil de
serrage écrou
bol blender
Ref #62980

ICE CRUSHER BROyeurs À GLAÇONS



09



Drawer
Tiroir
Ref #09502



Crushing disc
Disque de brise
glace
Ref #09201



53



Ice bucket
Bac à glaçons
Ref #53850

DRINK MIXER SHAKER ÉLECTRIQUE



54



Transparent bowl
Bol transparent
Ref #54105



Stainless steel bowl
Bol inox
Ref #54101



Spherical agitator
Agitateur
sphérique
Ref #54201



Winged agitator
Agitateur à
ailettes
Ref #54203



Soft agitator
Agitateur
souple
Ref #54202

BLENDER BLENDER



33



Complete bowl
Bol complet
Ref #33100



Complete blade
Ensemble couteaux
Ref #33107

Kitchen Equipment Équipements de cuisine

Your partner in food preparation since 1954. We offer a complete range of products for all needs, from the preparation of your appetizer to the creation of desserts.

Santos est votre partenaire en préparation culinaire depuis 1954. Nous offrons une gamme complète de produits qui répond à vos besoins, de la préparation de l'entrée jusqu'à la création du dessert.



12

Meat mincer

Prepare ground beef, hamburger steaks, sausages, and pâtés

Hachoir à viande

Préparez vos viandes hachées, saucisses, terrines...

Inspiration and precision



18

10 litre dough mixer

Knead your bread dough, pizza dough, shortcrust pastry...

Pétrin mélangeur 10 litres

Pétrissez vos pâtes à pain, pâte à pizza, pâte Brisée...

37

Kitchen blender

Make soups, gazpachos, purées, vegetable foams, creams...

Blender de cuisine

Réalisez des soupes, gazpachos, purées, mousses de légumes, crèmes, glaces...

02

Grater

Grate all kinds of cheese, dried fruit, peanuts...

Râpe

Râpez toutes sortes de fromages, fruits secs, arachides...

Unleash your creativity

LAISSEZ LIBRE COURS
À VOTRE CRÉATIVITÉ



02



02
Beige
Beige

Grater (1 standard disc Ø 3mm)

Râpe (1 disque standard Ø 3mm)

12-12R



12-12
Stainless
Steel
Inox



12-12R
Red
Rouge

Meat mincer

Stainless steel body.
Delivered with 3 plates Ø 70 mm

Hachoir à viande corps inox

Livré avec 3 grilles Ø 70 mm

18



18
Beige
Beige

10 litre dough mixer

Stainless steel bowl
The ideal dough mixer to make 4 kg of hard
dough

Pétrin mélangeur 10 litres

Cuve inox
Le pétrin idéal pour réaliser 4 kg de pâte dure

YOUR PARTNER IN THE KITCHEN

VOTRE PARTENAIRE
EN CUISINE

37 41



37 41
Grey
Gris



Santosafe kitchen blender painted base 37

Blender de cuisine Santosafe socle peint 37



CHOOSE YOUR OPTIONS

CHOISISSEZ VOS OPTIONS



21



2P



41



4P



Chef stick

Mix, liquefy and crush all kinds of hot and cold preparations:

- Powerful motor and new pulse function (18 000 rpm)
- High quality blending
- Exclusive patented Santosafe® locking system for the bowl and the cover

Mixez, émulsionnez et broyez toutes sortes de préparations chaudes ou froides :

- Moteur puissant et fonction pulse (18 000 tr/min)
- Qualité de mixage optimale
- Système de sécurité exclusif Santosafe® verrouillant le bol et le couvercle

Food equipment L'équipement cuisine

Our main accessories
Nos accessoires principaux

GRATER RÂPE



02



Grating disc 2mm
Disque 2mm
Ref #02201AD



Grating disc 3mm
Disque 3mm
Ref #02201BD



Grating disc 4mm
Disque 4mm
Ref #02201CD



Grating disc 6mm
Disque 6mm
Ref #02201DD



Grating disc 8mm
Disque 8mm
Ref #02201ED



Parmesan disc
Disque parmesan
Ref #02201FD



Fondue disc
Disque fondue
Ref #02201GD



Drawer
Tiroir
Ref #01502

MEAT MINCER HACHOIR À VIANDE



12-12R



Plate 3mm
Grille 3mm
Ref #12711



Plate 4,5mm
Grille 4,5mm
Ref #12712



Plate 8mm
Grille 8mm
Ref #12713B



Set of 3 sausage cones
Jeu de 3 cornets
à saucisses
Ref #12804

+



Plate 20 mm
Grille 20mm
Ref #12803

DOUGH MIXER PÉTRIN MÉLANGEUR



18



Complete bowl
Cuve complète
Ref #18500



Dough-hook
Fourche
Ref #18120

BLENDER BLENDER



37
—



**Complete 2L
Stainless Steel bowl**
Bol complet 2L inox
Ref #2I



**Complete
2L bowl**
Bol complet 2L
Ref #2P



**Complete 4L
Stainless Steel bowl**
Bol complet 4L inox
Ref #4I



Complete 4L bowl
Bol complet 4L
Ref #4P



Complete blade
Ensemble
couteaux
Ref #37180



Chef Stick
Chef Stick
Ref #37110

Coffee shop equipment

Équipements pour coffee shops

Santos has been manufacturing high-quality coffee grinders and grinding discs since 1954, for a perfect coffee.

- Quietest grinders on the market
- Constant dose dispensed
- Heat dissipation
- Anti-static system
- Easy adjustment and maintenance

Santos fabrique des moulins à café et meules de broyage depuis 1954, et offre des équipements de qualité pour un café parfait.

- Moulins les plus silencieux du marché
- Régularité de dose
- Dissipation thermique
- Système antistatique
- Réglages et maintenance faciles

Crunchy freeze
Frappé
Chilled latte
Chocolate
shake
iced coffee

Macchiato
Cappuccino
Latte special
Vanilla latte
Slow coffee



67

I-Grind coffee grinder
Create your own grinding

Moulin à café I-Grind
Personnalisez votre moulin

Quality and passion



59T

On-demand coffee grinder

Grind your coffee on-demand for a high-quality espresso

Moulin à café « on-demand »

Moulez votre café à la demande pour un espresso de qualité

01 BAR

Barista Coffee Grinder

Prepare your specialty coffee with this high precision grinder

Moulin à café Barista

Préparez vos cafés de spécialité avec une précision extrême

63

Coffee shop grinder

Ideal to quickly grind large quantities of coffee beans

Moulin à café coffee shop

Parfait pour moudre de grandes quantités de grains de café, en un temps record

Espresso coffee

CAFÉ
EXPRESSO



40 AN



8 kg/h



63 dB



40 AN
Black
Noir



40 A
Brown
Brun



Silent espresso coffee grinder

Available with mobile coffee tamper 40APPM

Moulin à café bar silencieux

Disponible avec presse-poudre mobile 40APPM

26



26
Black
Noir

Tabletop precision coffee dispenser

Doseur expresso de précision sur socle





Automatic
Automatique

55 BF



25 kg/h



63 dB



55W
White
Blanc



55 BF/BAR
Black
Noir



Automatic silent espresso coffee grinder
Black Front Panel 55 BF

Moulin à café espresso silencieux "automatique"
Façade noire 55 BF



New
Nouveauté

59 T



25 kg/h



63 dB



59W/59TW
White
Blanc



59/59T
Black
Noir



On-demand silent espresso coffee Grinder
Available without integrated tamper #59 / #59W

Moulin à café silencieux « on-demand »
Disponible sans tasseur intégré #59 / #59W

New
Nouveauté

67



63 dB



67
Black
Noir



I-Grind coffee grinder #67
Exclusive brushless technology

Moulin à café I-Grind #67
Technologie brushless exclusive

Coffee shop grinders

MOULINS À CAFÉ
BOUTIQUES
ET COFFEE SHOPS

01



01
Brown
Brun

Coffee grinder with drawer

Available with bag holder 01 PS, in pepper grinder version with drawer 01 P or in poppy grinder version 01 PV

Moulin à café tiroir

Disponible avec pince-sac 01 PS, en moulin à poivre - tiroir 01 P ou en moulin à pavot 01 PV

04 N



04N
Black
Noir



04
Brown
Brun



Coffee grinder with bag holder

Moulin à café Pince-sac



01 BAR



01 BAR
Black
Noir

Coffee Grinder – Championship Edition
1954 Barista series

Moulin à café Edition barista
1954 Barista series

63



120 kg/h



63
Black
Noir

Coffee shop grinder:

- Exceptional output: up to 120 kg/h
- Micrometric setting of the grinding fineness
- Makes turkish coffee (output: 36 kg/h)
- Extremely silent
- Santos Ø 120mm grinding discs

Moulin coffee shop :

- Débit exceptionnel : jusqu'à 120 kg/h
- Réglage de mouture micrométrique
- Permet de réaliser du café turc (débit : 36 kg/h)
- Extrêmement silencieux
- Meules Santos Ø 120 mm



Santos Ø 120 mm grinding discs

Santos offers the possibility to resharpen your grinding discs to give them a second life.

Meules Santos Ø 120 mm

Santos offre la possibilité de faire réaffûter vos meules pour leur donner une seconde vie.



43 N



43 N
Black
Noir

Silent shop coffee grinder with bag holder
Painted Black 43N

Moulin à café boutique silencieux Pince-sac
Noir 43N

Coffee shop Equipment

L'équipement coffee shop

Our main accessories

Nos accessoires principaux

01BAR, 04 N, 06A



01 BAR



04 N



1kg complete hopper
Bac à grains complet 1kg
Ref #01100



1kg complete black hopper
Bac à grains complet noir 1kg
Ref #01100N



01 BAR only
01 BAR uniquement

150g complete hopper
Bac à grains complet 150g
Ref #01115

01/01P



01



Drawer
Tiroir
Ref #01502



Complete hopper
Bac à grains complet
Ref #01100



Complete black hopper
Bac à grains complet noir
Ref #01100N

40 AN



40 AN



Coffee grinding receptacle
Récupérateur de café
Ref #40662B



2kg complete hopper
Bac à grains complet 2KG
Ref #40100



2kg complete cristal hopper
Bac à grains cristal complet 2KG
Ref #40100c

55



55



1kg complete hopper
Bac à grains complet 1KG
Ref #55130



Coffee grinding receptacle
Récupérateur de café
Ref #55662

59



59



1kg complete hopper
Bac à grains complet
1KG
Ref #59130



Coffee grinding receptacle
Récupérateur de café
Ref #59662

63



63



Grinding discs ø 120mm
Meules 120mm
Ref #00063

67



67



1kg complete hopper
Bac à grains complet
1KG
Ref #67102



Coffee grinding receptacle
Récupérateur de café
Ref #67550

01, 04, 06, 40, 42, 43, 55, 59 and 67 GRINDING DISCS MEULES

For every grinder except #63

Pour tous les moulins sauf n° 63



Poppy seeds discs
Meules pavot
Ref #00011



Pepper grinding discs
Meules poivre
Ref #00002N



Coffee grinding discs
Meules
Ref #00001B

40, 55, and 59 TOOL FOR GRINDER, FOR IMPACT DRIVER OUTIL DE DÉMONTAGE ÉCROU, POUR VISSEUSE



Tool for grinder, for impact driver
Outil de démontage écrou, pour visseuse
Ref #40981



Tool for grinder, manual
Outil de démontage écrou, manuel
Ref #40984

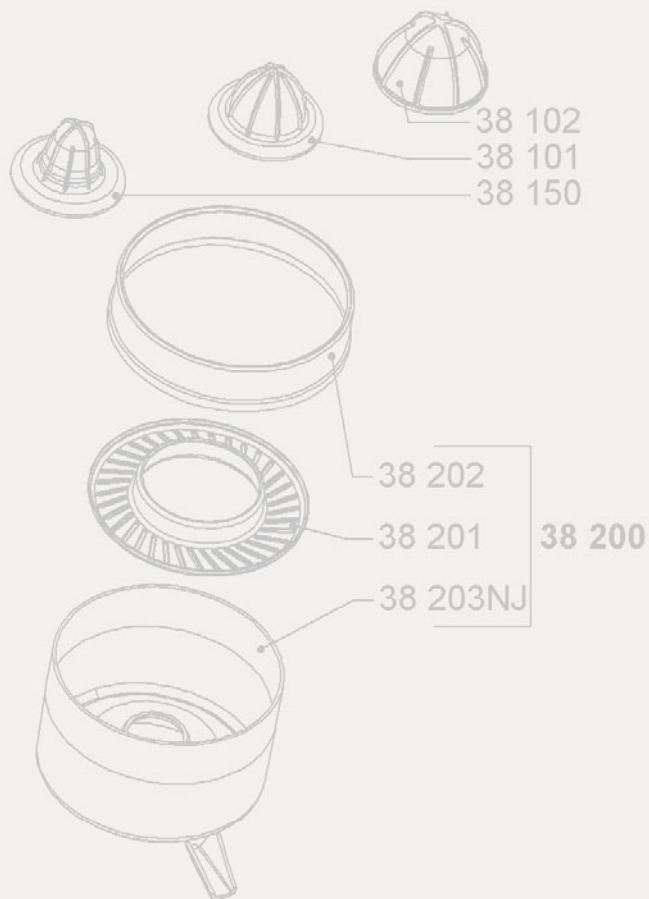

DONNÉES TECHNIQUES

Technical data

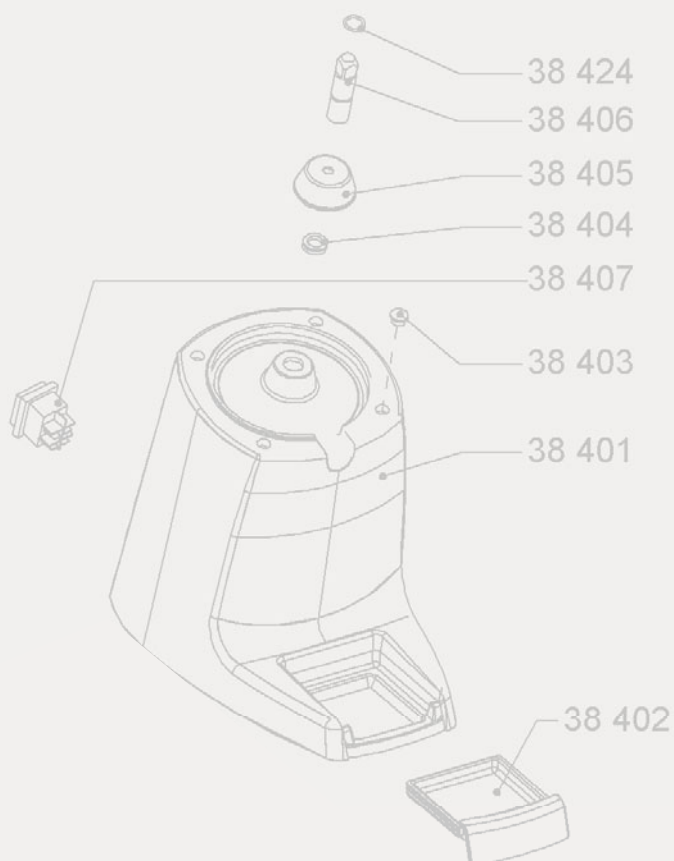

Juice Bar Equipment

Équipements pour bar à jus

	Reference Référence	Available voltages Voltage disponibles	Power Puissance (W)	Speed at 50Hz Vitesse à 50Hz (rpm; tr/min)	Specifications Spécifications	Standards Normes										Colors Couleurs			Dimensions (D x W x H) mm (P x L x H) mm	Net weight (kg) Poids net (kg)
						CE	GS	UL/ ETL	NSF	KC	EAC	Longtime	Stainless Steel Inox	Chrome Chromé	Black Noir	Grey Gris	Green Vert			
Citrus juicers Presse agrumes																				
71C	Mefra citrus juicer - chromed base (1 squeezer) Presse agrumes Mefra socle chromé (1 ogive)	71C	220-240V-50/60Hz	40	80	15 l/h	●												236x170x310	3,5
		71CV1	100-120V-50/60Hz	40																
11	“Classic” citrus juicer (3 squeezers) Presse agrumes « Classic » (3 ogives)	11 / 11G / 11C	220-240-50/60Hz	130	1450	30 l/h	●		●										300x230x350	5
		11V1 / 11GV1 / 11CV1	100-120V-50/60Hz	155																
38	Citrus juicer (3 squeezers) Presse agrumes (3 ogives)	38 / 38G / 38C	220-240-50/60Hz	130	1450	30 l/h	●		●										303x170x350	5
		38V1 / 38GV1 / 38CV1	100-120V-50/60Hz	155																
52	Citrus juicer - painted base (3 squeezers) Presse agrumes - socle peint (3 ogives)	52G / 52C	220-240-50/60Hz	230	1450	40 l/h	●		●	●									305x205x490	10
		52GV1 / 52CV1	100-120V-50/60Hz	260																
10	Automatic citrus juicer with lever Presse agrumes à levier	10 / 10C	220-240V-50/60Hz	230	1500	30 l/h	●		●										300x200x380	9,5
		10V1 / 10CV1	100-120V-50/60Hz	260																
70	Lever Juicer Evolution 70 (1 squeezer) Presse agrumes à levier 70 Evolution (1 ogive)	70 / 70C	220-240V-50/60Hz	300	1500	50 l/h	●		●										400x240x490	13,5
		70V1 / 70CV1	100-120V-50/60Hz	350																
Juice extractors Extracteur de jus par centrifugation																				
68	New generation centrifugal juice extractor “Miracle Edition” Extracteur nouvelle génération « Miracle Edition »	68 / 68X	220-240V-50/60Hz	1300	3000	140 l/h	●	●	●	●									490x330x603	25
		68V1	100-120V-50/60Hz	1300																
50	Centrifugal juice extractor Extracteur de jus par centrifugation	50 / 50C / 50X	220-240V-50/60Hz	800	3000	100 l/h	●		●										470x260x450	14
		50V1 / 50CV1	100-120V-50/60Hz	800																
28	Centrifugal juice extractor Extracteur de jus par centrifugation	28	220-240V-50/60Hz	1300	3000	100 l/h	●		●										465x320x510	24
		28V1	100-120V-50/60Hz																	
Cold Press Juicer Extracteur de jus à pression lente																				
65	Cold press juicer Extracteur de jus à pression lente	65	220-240V-50/60 Hz	400	5-70	60l/h	●		●										412x236x642	28,5
		65V1	100-120V-50/60 Hz				▲													

Standards | Normes :
 ● Approved | Approuvé
 ▲ Pending | En cours

Bar Equipment

Équipements de bar

	Reference Référence	Available voltages Voltage disponibles	Power Puissance (W)	Speed at 50Hz Vitesse à 50Hz (rpm; tr/min)	Specifications Spécifications	Standards Normes										Colors Couleurs				Dimensions (D x W x H) mm (P x L x H) mm	Net weight (kg) Poids net (kg)
						CE	UL / ETL	NSF	KC	EAC	Longtime	Stainless Steel Inox	Chrome Chromé	Black Noir	Grey Gris	Green Vert	Beige Beige				
Blenders, Drink mixers Mixeurs, Shakers électriques																					
62	Expert Brushless blender Blender Brushless Expert	62	220-240V-50/60Hz	1010	15000	2,4 l	●	▲	●	●	●	●	●	●	●	●	●	●	247x200x440	8,3	
		62V1	100-120V-50/60Hz	1010																	
66	Compact Brushless blender Blender Brushless Compact	66	220-240V-50/60Hz	1005	15000	2,4 l	●				●							233x197x393	6,2		
54	Drink mixer, electric shaker Shaker électrique, drink mixer	54 / 54R / 54G	220-240V-50/60Hz	230	8000 - 16000	0,675 l	●	●	●	●									186x182x530	6	
		54V1 / 54RV1 / 54GV1	100-120V-50/60Hz	230																	
33E	Bar blender Evolution – bowl detection Mixeur de bar Evolution – détection de bol	33E / 33GE / 33CE	220-240V-50/60Hz	600	12000 - 16000	1,25 l	●			●	●	●	●	●	●	●	●		180x180x420	3	
		33EV1/33GEV1/33CEV1	100-120V-50/60Hz	600																	
Ice crushers Broyeurs à glaçons																					
9	Ice shaver Broyeur à glaçons	09	220-240V-50Hz	600	1500	1,6 kg/min	●												420x250x350	14,5	
		09V4	220-240V-60Hz	600																	
		09V1	100-120V-50/60Hz	650																	
53	Ice crusher Broyeur à glaçons	53	220-240V-50/60Hz	130	73	24 kg/min	●			●									353x236x474	10	
		53V1	100-120V-50/60Hz																		
Cold drink dispensers Distributeurs de boissons																					
34-1	Cold drink dispenser (1 bowl x 12l) Distributeur de boissons réfrigérées (1 bac x 12 l)	34-1	220-240V-50/60Hz	130	-	12 l	●												430x190x545	15,5	
		34-1V1	100-120V-50/60Hz																		
34-2	Cold drink dispenser (2 bowls x 12l) Distributeur de boissons réfrigérées (2 bacs x 12 l)	34-2	220-240V-50/60Hz	335	-	2 x 12 l	●												430x380x545	23,5	
		34-2V1	100-120V-50/60Hz																		
34-3	Cold drink dispenser (3 bowls x 12l) Distributeur de boissons réfrigérées (3 bacs x 12 l)	34-3	220-240V-50/60Hz	470	-	3 x 12 l	●												430x570x545	30,5	
		34-3V1	100-120V-50/60Hz																		

Standards | Normes :
 ● Approved | Approuvé
 * Approved only for USA | Approuvé pour les Etats-Unis
 ▲ Pending | En cours

Kitchen Equipment

Équipements de cuisine

	Reference Référence	Available voltages Voltage disponibles	Power Puissance (W)	Speed at 50Hz Vitesse à 50Hz (rpm; tr/min)	Specifications Spécifications	Standards Normes				Colors Couleurs			Dimensions (D x W x H) mm (P x L x H) mm	Net weight (kg) Poids net (kg)
						CE	UL	EAC	Longtime	Stainless Steel Inox	Grey Gris	Beige		
Kitchen blender Blender de cuisine														
37	Santosafe® kitchen blender painted base only (without any bowl) Blender de cuisine Santosafe® socle peint (Base seule sans bol)	37	220-240V 50/60Hz	1550	0-18000	-	●	●	●	●			310x210x560	9
374P	Santosafe® kitchen blender painted base — 4 litre (1 gallon) transparent container Blender de cuisine Santosafe® socle peint — Bol 4 litres Polymère (sans bysphénol A)	374P	220-240V 50/60Hz	1550	0-18000	4L	●	●	●	●			310x210x560	11
374I	Santosafe® kitchen blender painted base — 4 litre (1 gallon) stainless steel container Blender de cuisine Santosafe® socle peint — Bol 4 litres Inox	374I	220-240V 50/60Hz	1550	0-18000	4L	●	●	●	●			310x210x560	11
372P	Santosafe® kitchen blender painted base — 2 litre (1/2 gallon) transparent container Blender de cuisine Santosafe® socle peint — Bol 2 litres Polymère (sans bysphénol A)	372P	220-240V 50/60Hz	1550	0-18000	2L	●	●	●	●			310x210x560	11
372I	Santosafe® kitchen blender painted base — 2 litre (1/2 gallon) stainless steel container Blender de cuisine Santosafe® socle peint — Bol 2 litres Inox	372I	220-240V 50/60Hz	1550	0-18000	2L	●	●	●	●			310x210x560	11
10 litre dough mixer and planetary mixer Pétrin et batteur mélangeur 10 litres														
18	10 litre dough mixer (kneader) stainless steel bowl Pétrin mélangeur 10 litres — cuve inox	18	220-240V-50Hz	600	70	4 kg	●	●	●	●	●	●	500x350x420	18,5
		18V1	100-120V-50/60Hz	650										
Grater Râpe														
02	Grater (1 standard disc) Râpe (1 disque standard)	02	220-240V-50Hz	600	1500	50 kg/h	●	●	●	●	●	●	420x250x350	14,5
		02V4	220-240V-60Hz	600										
		02V1	100-120V-50/60Hz	650										
Meat mincer Hachoir à viande														
12-12	Meat mincer — stainless steel mincer body Hachoir à viande — corps inox	12-12 / 12-12R	220-240V-50/60Hz	600	140	160 kg/h	●	●	●	●	●	●	350x260x420	19
		12-12V1 / 12-12RV1	100-120V-50/60Hz	650										

Standards | Normes :

- Approved | Approuvé
- * Approved only for USA | Approuvé pour les Etats-Unis
- ▲ Pending | En cours

Coffee Shop Equipment

Équipement pour Coffee shops

	Reference Référence	Available voltages Voltage disponibles	Power Puissance (W)	Speed at 50Hz Vitesse à 50Hz (rpm; tr/min)	Specifications Spécifications	Standards Normes				Colors Couleurs			Dimensions (DxWxH) mm (PxLxH) mm	Net weight (kg) Poids net (kg)	
						CE	UL	KC	EAC	Longtime	Stainless Steel Inox	Brown Brun			Black Noir
Espresso coffee grinders Moulin à café bar (espresso)															
40A	Autom. silent espresso coffee grinder Moulin à café bar doseur auto. silencieux	40A / 40AN / 40AG	220-240V-50Hz	360	1450	8 kg/h	●		●	●	●	●	390x190x580	14	
		40AV4 / 40ANV4 / 40AGV4	220-240V-60Hz	360											
		40AV1 / 40ANV1 / 40AGV1	100-120V-50/60Hz	310											
55BF	Automatic espresso coffee grinder Moulin à café espresso automatique	55BF	220-240V-50/60Hz	1150	2850	25 kg/h	●		●	●	●	397x198x577	15		
		55BFV1	100-120V-50/60Hz	800											
55BAR	Automatic espresso coffee grinder Moulin à café espresso automatique	55BAR	220-240V-50/60Hz	1150	2850	25 kg/h	●		●	●	●	397x198x577	15		
		55BARV1	100-120V-50/60Hz	800											
55W	Automatic espresso coffee grinder Moulin à café espresso automatique	55W	220-240V-50/60Hz	1150	2850	25 kg/h	●		●	●	●	397x198x577	15		
		55WV1	100-120V-50/60Hz	800											
59	On-demand coffee grinder Moulin à café « on-demand »	59	220-240V-50/60Hz	1150	2850	25 kg/h	●	▲	●	●	●	352x198x5740	14,9		
		59V1	100-120V-50/60Hz	800											
59W	On-demand coffee grinder Moulin à café « on-demand »	59W	220-240V-50/60Hz	1150	2850	25 kg/h	●	▲	●	●	●	352x198x5740	14,9		
		59WV1	100-120V-50/60Hz	800											
59T	On-demand coffee grinder Moulin à café « on-demand »	59T	220-240V-50/60Hz	1150	2850	25 kg/h	●	▲	●	●	●	352x198x5740	14,9		
		59TV1	100-120V-50/60Hz	800											
59TW	On-demand coffee grinder Moulin à café « on-demand »	59TW	220-240V-50/60Hz	1150	2850	25 kg/h	●	▲	●	●	●	352x198x5740	14,9		
		59TWV1	100-120V-50/60Hz	800											
67	More information coming soon Plus d'informations à venir														
Precision coffee dispenser Doseur Espresso de précision															
26	Tabletop precision coffee dispenser Doseur espresso de précision sur socle	-	-	-	-	-	●							293x200x352	4,3
Coffee shop grinders Moulin à café boutiques et coffee shops															
01	Coffee grinder with drawer or bag holder Moulin à café — tiroir ou pince-sac	01	220-240V-50Hz	600	1500	14 kg/h	●		●	●	●	320x250x550	14		
		01V4	220-240V-60Hz	600											
		01V1	100-120V-50/60Hz	650											
01P	Pepper (spices) grinder with drawer Moulin à poivre (épices) — tiroir	01P	220-240V-50Hz	600	1500	14 kg/h	●		●	●	●	320x250x550	14		
		01PV4	220-240V-60Hz	600											
		01PV1	100-120V-50/60Hz	650											
01 BAR	Coffee grinder championship edition Moulin à café édition barista	01 BAR	220-240V-50/60Hz	600	1500	14 kg/h	●		●	●	●	330x190x560	14,5		
			100-120V-50/60Hz												
04	Coffee grinder with bag holder Moulin à café — pince-sac	04	220-240V-50Hz	600	1500	14 kg/h	●		●	●	●	320x220x700	18		
		04V4	220-240V-60Hz	600											
		04V1	100-120V-50/60Hz	650											
43	Silent shop coffee grinder with bag holder Moulin à café boutique silencieux — pince-sac	43	220-240V-50Hz	600	1500	14 kg/h	●		●	●	●	350x190x685	20		
		43V4	220-240V-60Hz	600											
		43V1	100-120V-50/60Hz	650											
63	Coffee Shop Grinder Moulin à café Coffee Shop	63	220-240V-50Hz	1500	1500	120 kg/h	●		●	●	●	329x265x677	40		
		63V4	220-240V-60Hz												
		63V1	100-120V-50/60Hz												

Standards | Normes :
 ● Approved | Approuvé
 ▲ Pending | En cours



Food and Beverage
Equipment Provider



140-150, avenue Roger
Salengro — BP 80 067
69511 Vaulx-en-Velin
Cedex (Lyon) France

Tél. : +33 4 72 37 35 29
Fax : +33 4 78 26 58 21
E-mail : santos@santos.fr
www.santos.fr

Follow us on **#santosaddict**
social networks

